

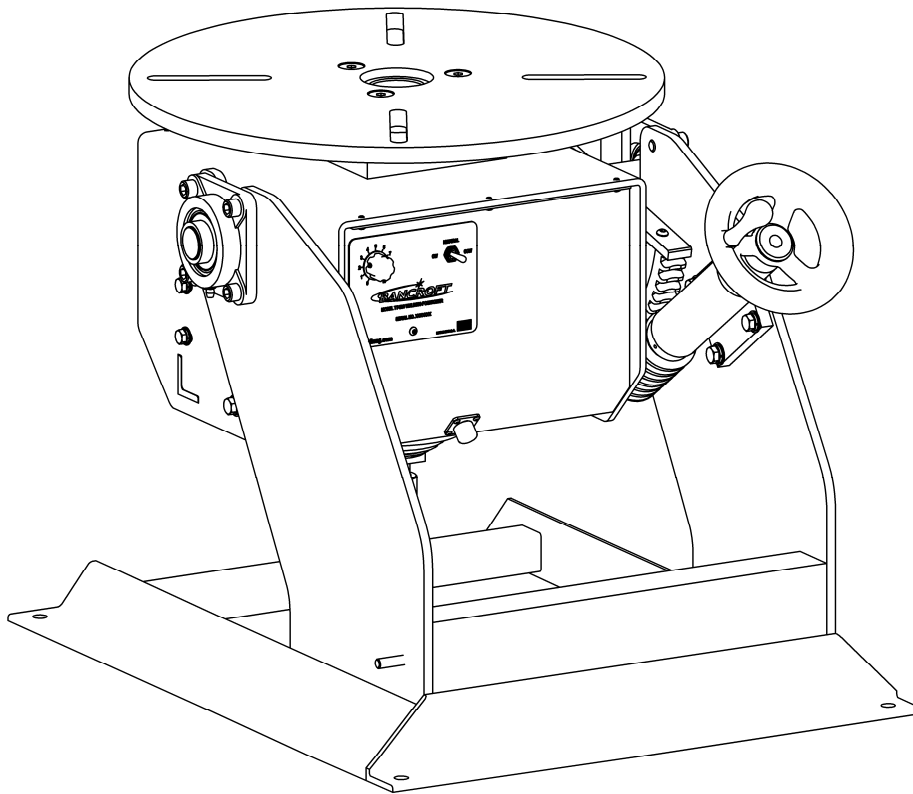

WELDING POSITIONER OPERATION MANUAL MODEL TT-500 V1.0



Carefully read and understand these operation instructions before operating, inspecting, or servicing this product.

This manual for use with Serial Numbers 201001 and following



TABLE OF CONTENTS

1.	SAFETY INFORMATION.....	3
2.	PACKING LIST.....	4
3.	INSPECTION CHECKLIST.....	4
4.	MACHINE OVERVIEW.....	5
5.	INSTALLATION.....	6
6.	OPERATIONS.....	7
7.	HANDLING MOUNTED OBJECTS.....	8
8.	TROUBLESHOOTING.....	8
9.	DAILY MAINTENANCE.....	8
10.	WARRANTY.....	9
11.	ELECTRICAL SCHEMATICS.....	10
12.	PARTS LIST.....	12

SAFETY INFORMATION



ELECTRICAL SHOCK CAN CAUSE INJURY OR DEATH

Electrical equipment must be installed and maintained in accordance with the National Electrical Code, NFPA 70, and all local codes. Maintain Mig-Guns, Electrode Holders, Tig Torches, Plasma Torches, Work Clamp, Welding Cable, and Welding Machines in good, safe operating condition. Replace worn or damaged insulation. Do not try to repair or service equipment while the power is still on. Do not service or repair equipment unless you are trained and qualified to do so. The Electrode and Work (or Ground) circuits are electrically "HOT" when equipment power is on. At no time should you touch the Electrode and Electrical Ground at the same time with bare skin or wet clothing while the power is on. Insulate yourself from work and ground using dry insulation. Keep gas cylinders, chains, wire ropes, hoists, cranes, and elevators away from any part of the electrical path. Always be sure the work cable makes a good electrical connection with the metal being welded. Occasionally check all ground connections to determine if they are mechanically strong and electrically adequate for the current required. The ground connection should be as close as possible to the area being welded. When not welding for any substantial period, make certain that no part of the electrode circuit will accidentally make contact with the work or ground.



SMOKE, FUMES, AND GASES CAN BE DANGEROUS TO YOUR HEALTH

Keep smoke, fumes, and gases from your breathing zone and the general area. Smoke, fumes, and gases from the welding or cutting process are of various types and strengths. To ensure your safety, do not breathe these fumes or gases. Ventilation must be adequate to remove smoke, fumes, and gases during the welding procedure to protect operators and others in the immediate area. **Never Ventilate with Oxygen**, because oxygen supports and vigorously accelerates fire.



HOT PARTS

Hot parts can cause serious burns. The area at and near the work being welded should be handled with proper gloves. Proper clothing should be worn to prevent spatter or chipped slag from causing burns. Never pick up welded material until it has properly cooled.



MOVING PARTS MAY CAUSE INJURY

Have only qualified people remove guards or covers for performing maintenance and troubleshooting. Moving parts such as gears can maim fingers or hands and catch loose clothing. Keep tools, hands, hair and clothing away from moving parts. Be sure to reinstall all panels and guards before operating equipment.



FALLING EQUIPMENT

Lift only the unit to be moved without any running gear or accessories that may be attached to it. Use equipment of a proper size to lift and move the unit. Falling equipment can cause personal injury and equipment damage.

IMPORTANT - Protect yourself and others! Remember that safety depends on you. The operator, supervisor, and helper must read and understand all warning and safety information provided in these instructions. **Severe injury or death** could result if equipment is not properly installed, used and maintained. Training and proper supervision are most important for a safe work place. Installation, operation, repair work, and maintenance must be performed by qualified personnel. Retain these instructions for future use.

Bancroft Engineering, LLC

21550 Doral Road Waukesha, WI 53186

Phone: (262)786-1880

www.bancrofteng.com



TT-500 Welding Positioner

PACKING LIST

Confirm the supplied items

Before using this product, confirm all items ordered are included in the packaging. In the event an item is missing, please contact Bancroft Engineering or the dealer where you purchased the product.

ITEM NAME	QUANTITY	REMARKS
Positioner Main Unit	1	
Power Cable	1	
Operating Instructions	1	This Manual
T-nuts & Studs	4	Optional
Chuck	1	Optional
Foot Switch	1	Optional
Digital Display	1	Optional

PRE-SHIP INSPECTION LIST

Checklist of pre-ship tests and inspections

Inspection	OK	Deficient	Comments
Low Speed Confirmation			
High Speed Confirmation			
CW-OFF-CCW Switch Confirmation			
1 Hour test run completed			
Spindle nut torque confirmed after run-in (13.2 ft-lbs)			
Optional Foot pedal test completed			

Inspector Initials _____

Bancroft Engineering, LLC

21550 Doral Road Waukesha, WI 53186

Phone: (262)786-1880

www.bancrofteng.com

MACHINE OVERVIEW

The positioner is designed and intended to help position a workpiece for steady welding. It rotates a table using a motor and lets you adjust the speed and rotational direction using a control dial and 3 position switch. An optional foot switch can be used to start/stop the rotation.

The table can be set to the necessary tilt angle using tilt adjustment handle.



NEVER ADJUST THE TILT ANGLE WITH WORK RESTING ON THE TABLE! REMOVE ALL MATERIAL INCLUDING ANY WORK PIECE HOLDING BEFORE ADJUSTING TILT ANGLE.

SPECIFICATIONS

Max Load (lbs)	Horizontal	500
	Vertical	250
Power Supply		110V 60Hz AC
External Dimensions		21-13/16 x 27 x 24
Height x Width x Depth (in)		
Table Diameter (in)		20
Table Rotation (RPM)	Minimum	0
	Max	15.75
Tilt Angle (Degrees)		-10 to 110
Center of Gravity during Max Load (in)	Height	4.0
	Eccentricity	2.0
Table Height in Horizontal Position (in)		21-13/16"
Tilt Axis Height (in)		17.25
Weight of main unit (lbs)		~260
Allowable welding current (A)		500 @ max rpm

Positioner Dimensional Drawings

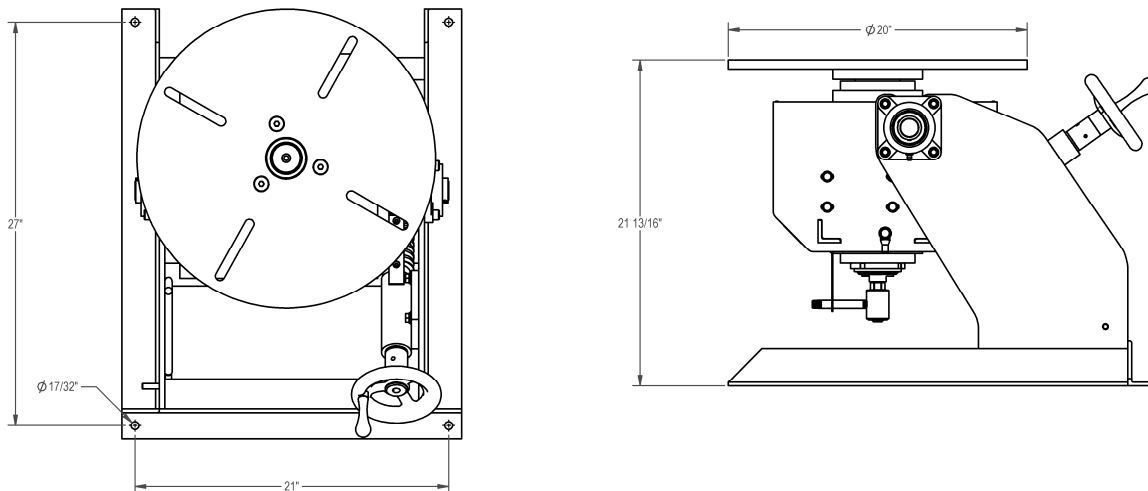

Bancroft Engineering, LLC

21550 Doral Road Waukesha, WI 53186

Phone: (262)786-1880

www.bancrofteng.com

INSTALLATION

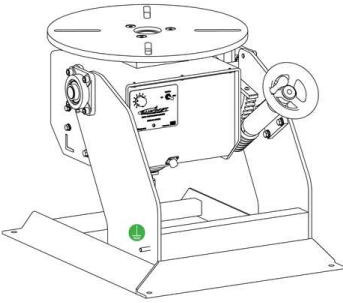
1. Confirm the packaged components (See Packing List, page 4)
 2. Installation Location
 - a. Well-ventilated location. Fumes and gases must be ventilated during welding.
 - b. Flat surface that is strong enough to support the weights of the mounted items and the positioner. If the surface or floor is weak, unbalanced loads may cause the positioner to fall over.
 - c. **DO NOT PLACE THE POSITIONER IN THE FOLLOWING LOCATIONS**
 - i. ANY LOCATION SUBJECT TO WATER
 - ii. LOCATIONS SUBJECT TO HIGH TEMPERATURES
 - iii. LOCATIONS NEAR DANGEROUS INFLAMMABLE OBJECTS
 - iv. LOCATIONS WHERE WELDING SPARKS AND SPATTERS MAY CAUSE FIRE
 3. Equipment Installation
 - a. Installing the main unit
 - i. Place the main unit on a flat installation location.
 - ii. Secure the unit by inserting 5/16" or 10mm anchor bolts in the four holes around the base of the unit.
 - b. Connecting the foot switch (Optional)
 - i. Remove protective cap.
 - ii. Connect the cable of the foot switch to the mating plug on the main unit. Secure the connection with the locking nut.
 4. Earth ground conductor and work lead
 - a. Properly connect the earth ground conductor on the positioner main unit (labeled with a  sticker)
 - b. Directly attach the welding ground cable/work lead for the power supply to the ground stud on positioner, and secure it with a nut.
- 
- WARNING:** Be sure to connect the earth ground conductor to prevent an electric shock.
5. Connecting the Power Supply
 - a. Use specified power supply only.
 - i. Route the power supply cable so it will not be stepped on and in a location where nothing will be placed on top of the cable.
 - ii. Connect the power supply cable only after confirming the safety of the surrounding area.
 - iii. Ground the power supply cable properly, and fully plug into the receptacle.
 - iv. Do not connect the earth conductor to a conduit, water pipe, or gas pipe.
 - v. Supply power only after confirming the toggle switch is in the "off" position.

Bancroft Engineering, LLC

21550 Doral Road Waukesha, WI 53186

Phone: (262)786-1880

www.bancrofteng.com

OPERATIONS

1. Control Functions

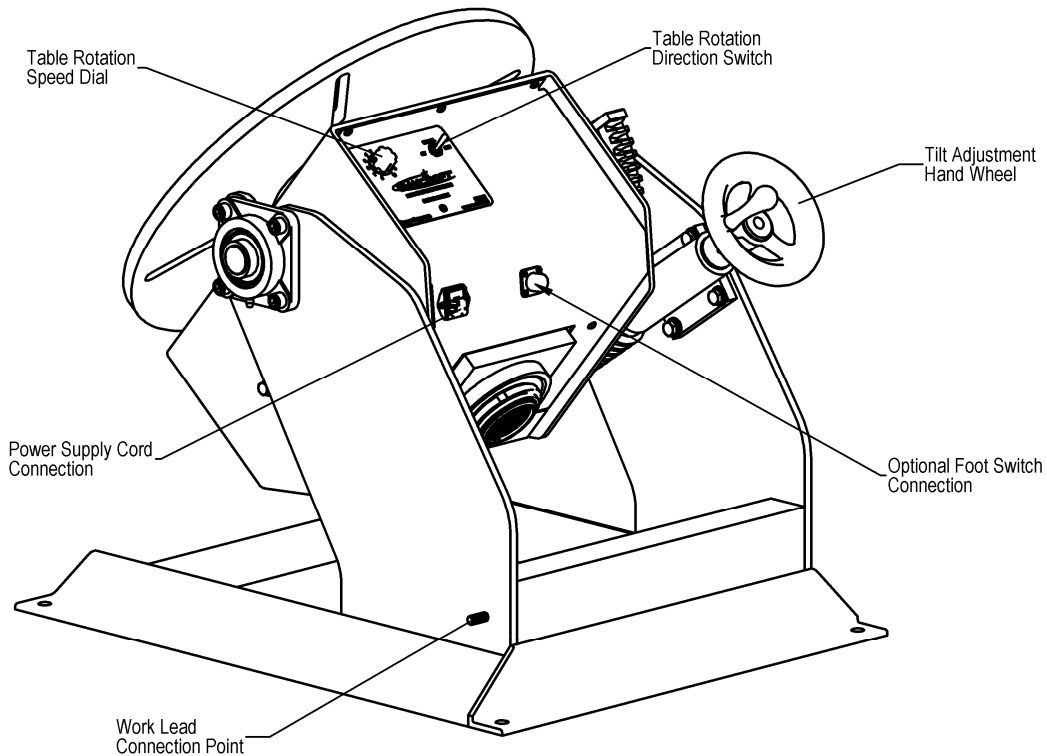

2. Operational Procedure

Main Unit	
1	Turn on buildings main power supply and the power to the positioner.
2	Adjust the table angle to desired location.
3	Attach a workpiece to the table.
4	Set the rotational speed to 2.
5	Select the direction of rotation using the 3 position switch.
6	If optional foot pedal is connected, press pedal to start rotation.
7	Adjust the rotation speed as needed.
8	Perform welding work.
9	Turn off the unit.
10	Remove the workpiece.



This positioner is made to control TIG welding noise, but to ensure safety, use separate power supplies for the main unit and the welding power. During operation, do not allow the main unit cable and torch cable to cross each other.

Bancroft Engineering, LLC

21550 Doral Road Waukesha, WI 53186

Phone: (262)786-1880

www.bancrofteng.com



HANDLING MOUNTED OBJECTS

1. When attaching work, always wear proper personal protective equipment including a helmet, protective glasses, and safety shoes.
2. Attach and align workpieces properly
3. Check the surrounding area for impediments before starting table rotation.
4. When placing a workpiece on the table be careful not to create a large impact.
5. Do not place a load exceeding the max allowable load, this includes all work holding tooling.

TROUBLESHOOTING

PROBLEM	POSSIBLE CAUSE	SOLUTION
Table does not rotate.	<ol style="list-style-type: none"> 1 Power cord is not properly secured 2 Blown Fuse 3 Power cord damaged 4 Switch or foot switch malfunction 5 Faulty control board 6 Faulty motor 7 Bearing damage 	Secure properly Replace fuse Replace the power cord Replace the component Replace the control board Replace the motor Replace the bearing assembly
Fuse Blown	<ol style="list-style-type: none"> 1 Faulty control board 2 Faulty motor 3 Bad power supply 4 Power cord damaged 	Replace the control board Replace the motor Replace fuse and try different power supply Replace the power cord
Table does not rotate smoothly.	<ol style="list-style-type: none"> 1 Bearing nut is loose 2 Bearing damage 3 Spatter from welding adhered to the gears 	Torque bearing nut to 13.2 ft-lbs Replace the bearing assembly Clean and apply grease to the gears
Table will not tilt	<ol style="list-style-type: none"> 1 Seized Adjustment Handle 	Lubricated and move in both directions to free up.

DAILY MAINTENANCE

- ✦ Inspect table ground for proper tension against table.
- ✦ Test operation of 3 position power switch
- ✦ Test operation of optional foot pedal if provided
- ✦ Check for any broken wires or loose connections
- ✦ Check for any damaged or worn parts



TT-500 Welding Positioner

WARRANTY

LIMITED WARRANTY: Subject to the terms and conditions hereof, **Bancroft Engineering**, Waukesha, WI warrants its products to be free from defects in workmanship and material at the time of delivery. **Bancroft Engineering** will honor warranty claims on products as a result of failure from a defect for a time period of 90 days from the date of sale to the original user. Upon return of the merchandise at the user's expense, **Bancroft Engineering** reserves the right to either repair or replace as necessary. This is the only warranty either expressed or implied covering this product.

Bancroft Engineering, LLC
21550 Doral Road Waukesha, WI 53186
Phone: (262)786-1880
www.bancrofteng.com

ELECTRICAL SCHEMATICS (1)

Main Control Board Wiring Diagram.

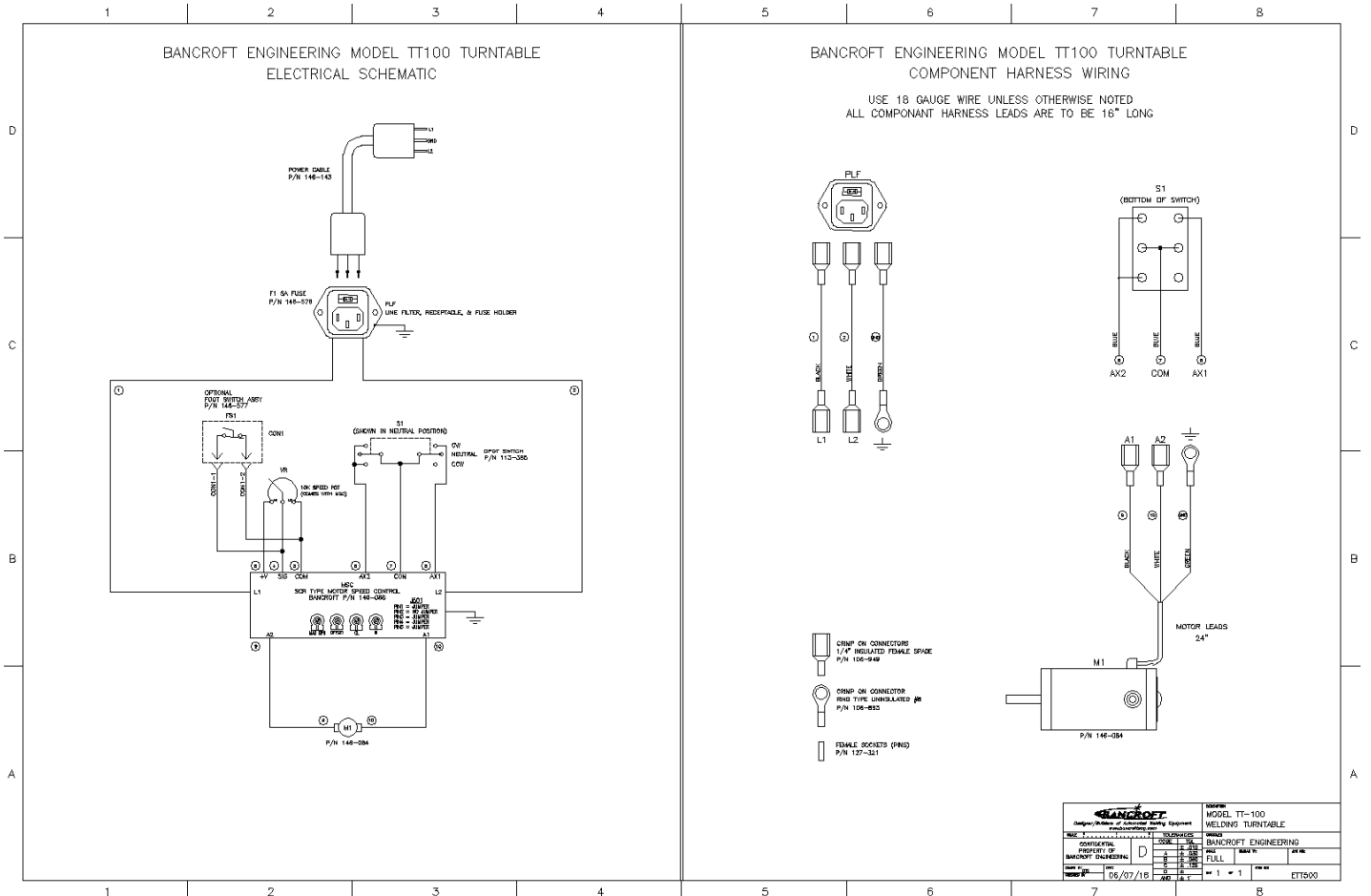

Service or repair of this unit must be done by qualified personnel only.



Before performing any maintenance on this control board disconnect the unit from any power supply.

ELECTRICAL SCHEMATICS (2)

Optional Foot Switch Wiring Diagram.

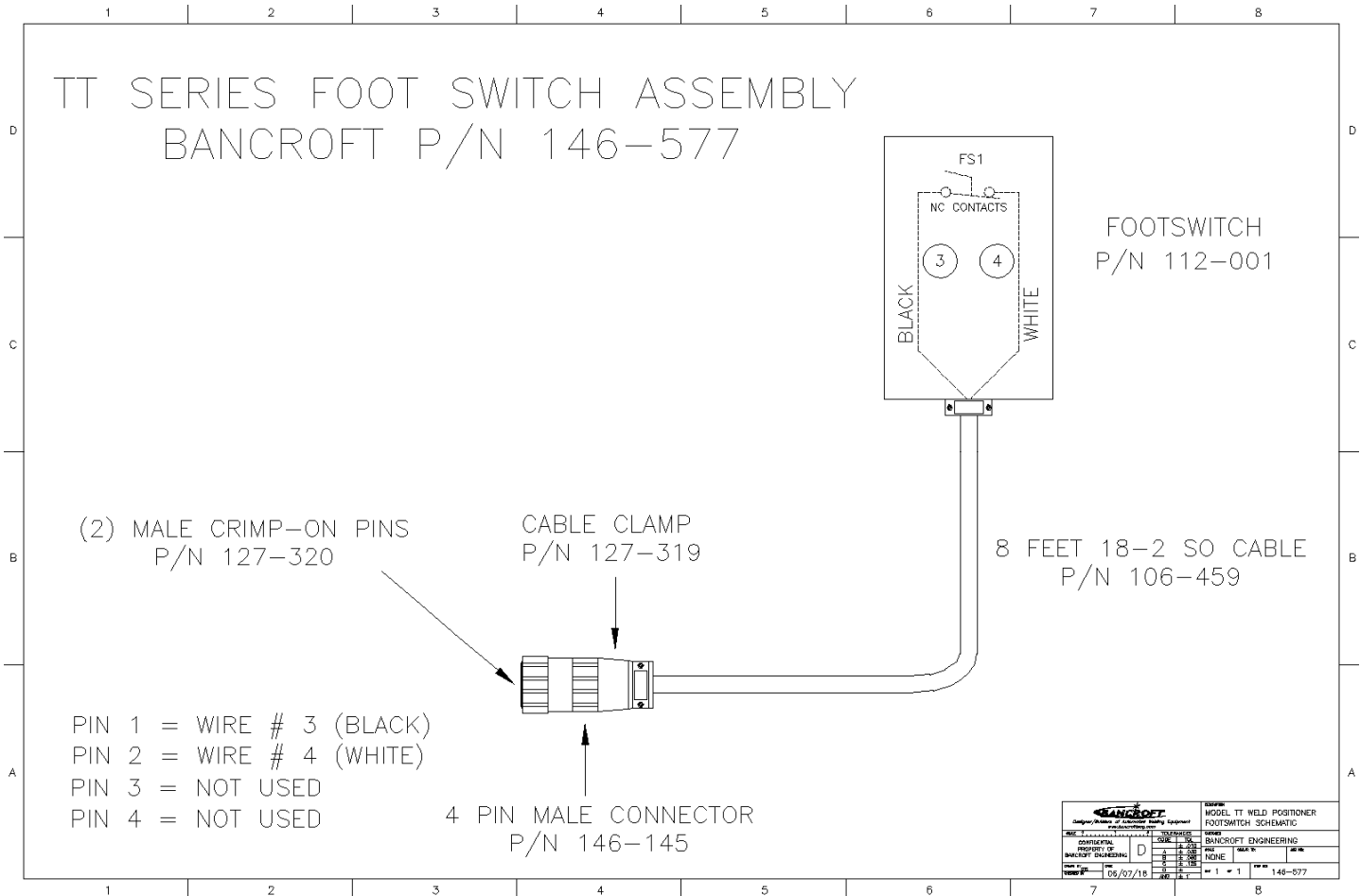

Service or repair of this unit must be done by qualified personnel only.



Before performing any maintenance on this control board disconnect the unit from any power supply.

PARTS LIST

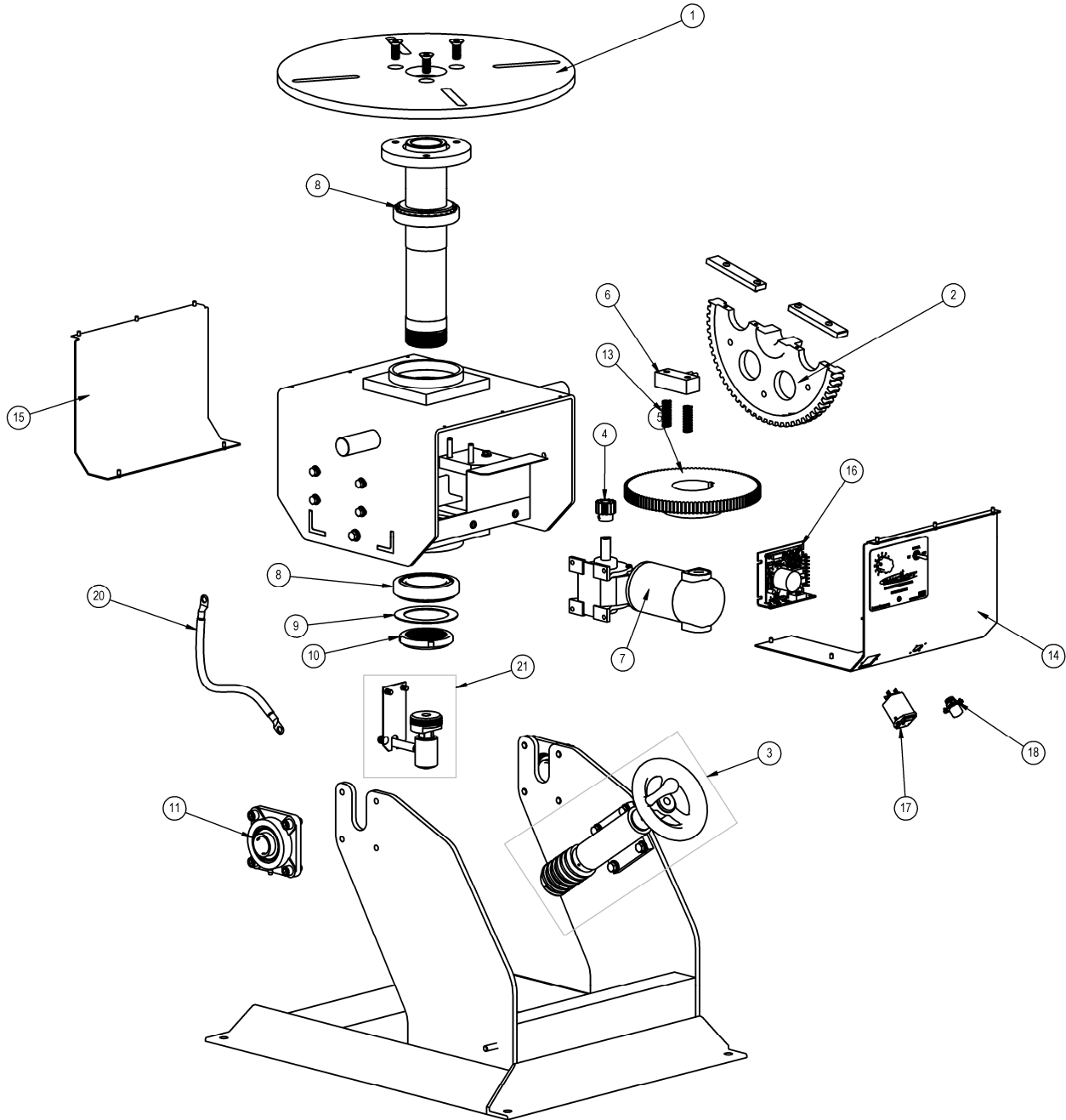

Bancroft Engineering, LLC
 21550 Doral Road Waukesha, WI 53186
 Phone: (262)786-1880
 www.bancrofteng.com



TT-500 Welding Positioner

ITEM	PART NO.	QTY	DESCRIPTION
1	146-898	1	Positioner Work Table
2	147-043	1	Worm Gear
3	127-703	1	Tilt Worm Assembly
4	147-280	1	Spur Gear, 14tooth, 12pitch, 14.5°PA
5	147-038	1	Spur Gear, Ø2.75 bore
6	104-259	1	Ground Brush Block
7	147-279	1	DC Gearmotor
8	147-034	2	Tapered Roller Bearing Ø2.75
9	147-095	1	Steel Shim Ø4.5 OD x Ø3 ID x .075 Thk.
10	131-621	1	Bearing Locknut, 2.751-18
11	147-039	2	Flange Bearing, 4-bolt, Ø1.25
12	147-030	1	Ground Brush Mtg. Block
13	119-789	2	Compression Spring
14	147-032	1	Control Plate / Cover
15	147-033	1	Back Cover
16	146-088	1	Speed Controller Assembly, Pre-wired
17	146-501	1	EMI Filter / Power Plug
18	146-144	1	4-Pin Receptacle
19	146-576	1	Fuse 5x20mm 5A Time Delay
20	147-282	1	Ground Cable
21	147-041	1	Purge Adapter OPTION

Bancroft Engineering, LLC

21550 Doral Road Waukesha, WI 53186

Phone: (262)786-1880

www.bancrofteng.com



WELDING POSITIONER OPERATION MANUAL MODEL TT-500 V1.0

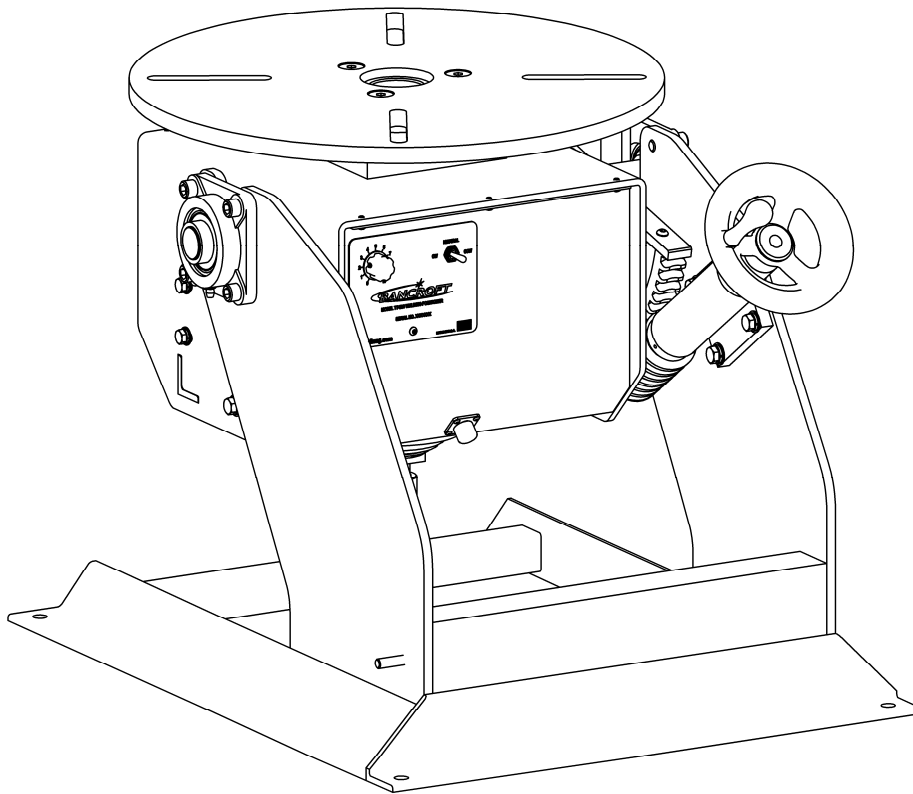

Carefully read and understand these operation instructions before operating, inspecting, or servicing this product.

This manual for use with Serial Numbers 201001 and following



TABLE OF CONTENTS

1.	SAFETY INFORMATION.....	3
2.	PACKING LIST.....	4
3.	INSPECTION CHECKLIST.....	4
4.	MACHINE OVERVIEW.....	5
5.	INSTALLATION.....	6
6.	OPERATIONS.....	7
7.	HANDLING MOUNTED OBJECTS.....	8
8.	TROUBLESHOOTING.....	8
9.	DAILY MAINTENANCE.....	8
10.	WARRANTY.....	9
11.	ELECTRICAL SCHEMATICS.....	10
12.	PARTS LIST.....	12

SAFETY INFORMATION



ELECTRICAL SHOCK CAN CAUSE INJURY OR DEATH

Electrical equipment must be installed and maintained in accordance with the National Electrical Code, NFPA 70, and all local codes. Maintain Mig-Guns, Electrode Holders, Tig Torches, Plasma Torches, Work Clamp, Welding Cable, and Welding Machines in good, safe operating condition. Replace worn or damaged insulation. Do not try to repair or service equipment while the power is still on. Do not service or repair equipment unless you are trained and qualified to do so. The Electrode and Work (or Ground) circuits are electrically "HOT" when equipment power is on. At no time should you touch the Electrode and Electrical Ground at the same time with bare skin or wet clothing while the power is on. Insulate yourself from work and ground using dry insulation. Keep gas cylinders, chains, wire ropes, hoists, cranes, and elevators away from any part of the electrical path. Always be sure the work cable makes a good electrical connection with the metal being welded. Occasionally check all ground connections to determine if they are mechanically strong and electrically adequate for the current required. The ground connection should be as close as possible to the area being welded. When not welding for any substantial period, make certain that no part of the electrode circuit will accidentally make contact with the work or ground.



SMOKE, FUMES, AND GASES CAN BE DANGEROUS TO YOUR HEALTH

Keep smoke, fumes, and gases from your breathing zone and the general area. Smoke, fumes, and gases from the welding or cutting process are of various types and strengths. To ensure your safety, do not breathe these fumes or gases. Ventilation must be adequate to remove smoke, fumes, and gases during the welding procedure to protect operators and others in the immediate area. **Never Ventilate with Oxygen**, because oxygen supports and vigorously accelerates fire.



HOT PARTS

Hot parts can cause serious burns. The area at and near the work being welded should be handled with proper gloves. Proper clothing should be worn to prevent spatter or chipped slag from causing burns. Never pick up welded material until it has properly cooled.



MOVING PARTS MAY CAUSE INJURY

Have only qualified people remove guards or covers for performing maintenance and troubleshooting. Moving parts such as gears can maim fingers or hands and catch loose clothing. Keep tools, hands, hair and clothing away from moving parts. Be sure to reinstall all panels and guards before operating equipment.



FALLING EQUIPMENT

Lift only the unit to be moved without any running gear or accessories that may be attached to it. Use equipment of a proper size to lift and move the unit. Falling equipment can cause personal injury and equipment damage.

IMPORTANT - Protect yourself and others! Remember that safety depends on you. The operator, supervisor, and helper must read and understand all warning and safety information provided in these instructions. **Severe injury or death** could result if equipment is not properly installed, used and maintained. Training and proper supervision are most important for a safe work place. Installation, operation, repair work, and maintenance must be performed by qualified personnel. Retain these instructions for future use.

Bancroft Engineering, LLC

21550 Doral Road Waukesha, WI 53186

Phone: (262)786-1880

www.bancrofteng.com



TT-500 Welding Positioner

PACKING LIST

Confirm the supplied items

Before using this product, confirm all items ordered are included in the packaging. In the event an item is missing, please contact Bancroft Engineering or the dealer where you purchased the product.

ITEM NAME	QUANTITY	REMARKS
Positioner Main Unit	1	
Power Cable	1	
Operating Instructions	1	This Manual
T-nuts & Studs	4	Optional
Chuck	1	Optional
Foot Switch	1	Optional
Digital Display	1	Optional

PRE-SHIP INSPECTION LIST

Checklist of pre-ship tests and inspections

Inspection	OK	Deficient	Comments
Low Speed Confirmation			
High Speed Confirmation			
CW-OFF-CCW Switch Confirmation			
1 Hour test run completed			
Spindle nut torque confirmed after run-in (13.2 ft-lbs)			
Optional Foot pedal test completed			

Inspector Initials _____

Bancroft Engineering, LLC

21550 Doral Road Waukesha, WI 53186

Phone: (262)786-1880

www.bancrofteng.com

MACHINE OVERVIEW

The positioner is designed and intended to help position a workpiece for steady welding. It rotates a table using a motor and lets you adjust the speed and rotational direction using a control dial and 3 position switch. An optional foot switch can be used to start/stop the rotation.

The table can be set to the necessary tilt angle using tilt adjustment handle.



NEVER ADJUST THE TILT ANGLE WITH WORK RESTING ON THE TABLE! REMOVE ALL MATERIAL INCLUDING ANY WORK PIECE HOLDING BEFORE ADJUSTING TILT ANGLE.

SPECIFICATIONS

Max Load (lbs)	Horizontal	500
	Vertical	250
Power Supply		110V 60Hz AC
External Dimensions		21-13/16 x 27 x 24
Height x Width x Depth (in)		
Table Diameter (in)		20
Table Rotation (RPM)	Minimum	0
	Max	15.75
Tilt Angle (Degrees)		-10 to 110
Center of Gravity during Max Load (in)	Height	4.0
	Eccentricity	2.0
Table Height in Horizontal Position (in)		21-13/16"
Tilt Axis Height (in)		17.25
Weight of main unit (lbs)		~260
Allowable welding current (A)		500 @ max rpm

Positioner Dimensional Drawings

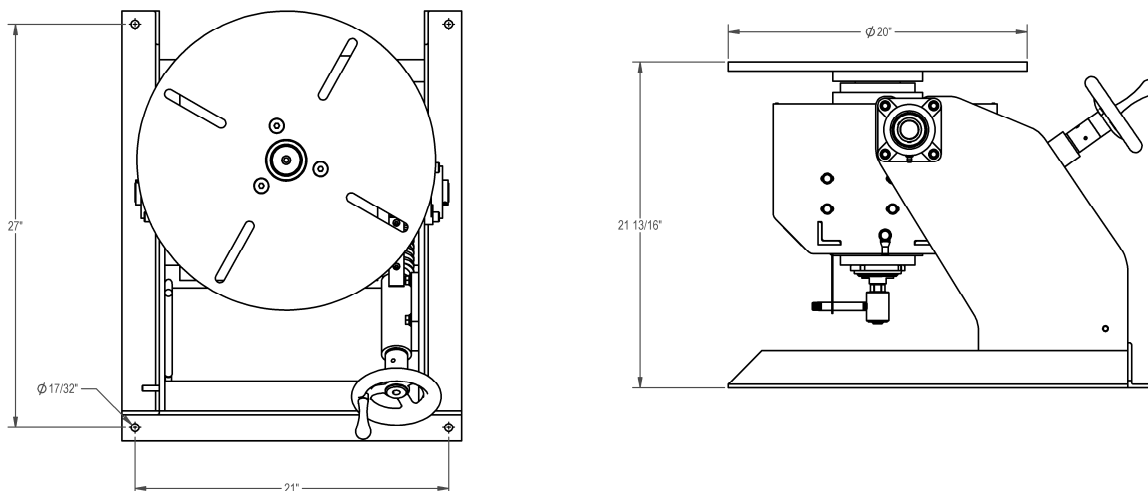

Bancroft Engineering, LLC

21550 Doral Road Waukesha, WI 53186

Phone: (262)786-1880

www.bancrofteng.com

INSTALLATION

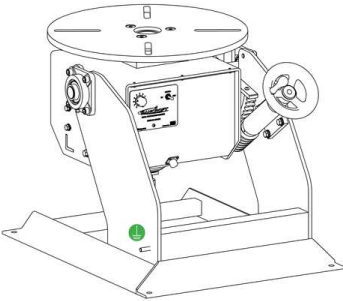
1. Confirm the packaged components (See Packing List, page 4)
 2. Installation Location
 - a. Well-ventilated location. Fumes and gases must be ventilated during welding.
 - b. Flat surface that is strong enough to support the weights of the mounted items and the positioner. If the surface or floor is weak, unbalanced loads may cause the positioner to fall over.
 - c. **DO NOT PLACE THE POSITIONER IN THE FOLLOWING LOCATIONS**
 - i. ANY LOCATION SUBJECT TO WATER
 - ii. LOCATIONS SUBJECT TO HIGH TEMPERATURES
 - iii. LOCATIONS NEAR DANGEROUS INFLAMMABLE OBJECTS
 - iv. LOCATIONS WHERE WELDING SPARKS AND SPATTERS MAY CAUSE FIRE
 3. Equipment Installation
 - a. Installing the main unit
 - i. Place the main unit on a flat installation location.
 - ii. Secure the unit by inserting 5/16" or 10mm anchor bolts in the four holes around the base of the unit.
 - b. Connecting the foot switch (Optional)
 - i. Remove protective cap.
 - ii. Connect the cable of the foot switch to the mating plug on the main unit. Secure the connection with the locking nut.
 4. Earth ground conductor and work lead
 - a. Properly connect the earth ground conductor on the positioner main unit (labeled with a  sticker)
 - b. Directly attach the welding ground cable/work lead for the power supply to the ground stud on positioner, and secure it with a nut.
- 
- WARNING:** Be sure to connect the earth ground conductor to prevent an electric shock.
5. Connecting the Power Supply
 - a. Use specified power supply only.
 - i. Route the power supply cable so it will not be stepped on and in a location where nothing will be placed on top of the cable.
 - ii. Connect the power supply cable only after confirming the safety of the surrounding area.
 - iii. Ground the power supply cable properly, and fully plug into the receptacle.
 - iv. Do not connect the earth conductor to a conduit, water pipe, or gas pipe.
 - v. Supply power only after confirming the toggle switch is in the "off" position.

Bancroft Engineering, LLC

21550 Doral Road Waukesha, WI 53186

Phone: (262)786-1880

www.bancrofteng.com

OPERATIONS

1. Control Functions

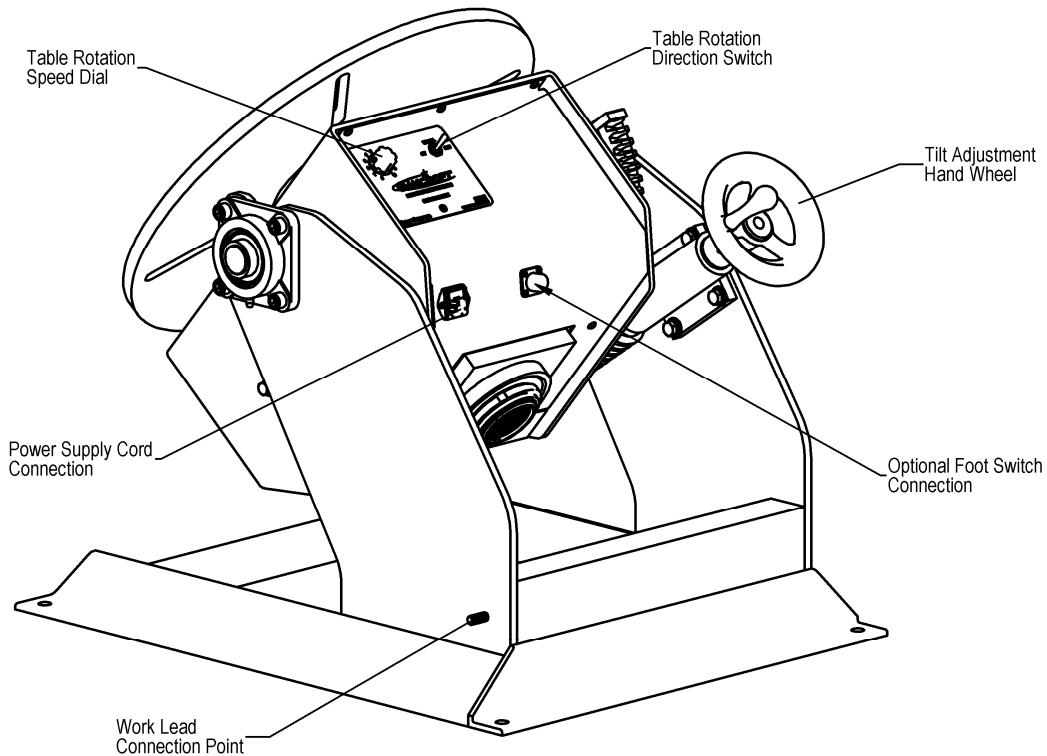

2. Operational Procedure

Main Unit	
1	Turn on buildings main power supply and the power to the positioner.
2	Adjust the table angle to desired location.
3	Attach a workpiece to the table.
4	Set the rotational speed to 2.
5	Select the direction of rotation using the 3 position switch.
6	If optional foot pedal is connected, press pedal to start rotation.
7	Adjust the rotation speed as needed.
8	Perform welding work.
9	Turn off the unit.
10	Remove the workpiece.



This positioner is made to control TIG welding noise, but to ensure safety, use separate power supplies for the main unit and the welding power. During operation, do not allow the main unit cable and torch cable to cross each other.

Bancroft Engineering, LLC

21550 Doral Road Waukesha, WI 53186

Phone: (262)786-1880

www.bancrofteng.com



HANDLING MOUNTED OBJECTS

1. When attaching work, always wear proper personal protective equipment including a helmet, protective glasses, and safety shoes.
2. Attach and align workpieces properly
3. Check the surrounding area for impediments before starting table rotation.
4. When placing a workpiece on the table be careful not to create a large impact.
5. Do not place a load exceeding the max allowable load, this includes all work holding tooling.

TROUBLESHOOTING

PROBLEM	POSSIBLE CAUSE	SOLUTION
Table does not rotate.	<ol style="list-style-type: none"> 1 Power cord is not properly secured 2 Blown Fuse 3 Power cord damaged 4 Switch or foot switch malfunction 5 Faulty control board 6 Faulty motor 7 Bearing damage 	Secure properly Replace fuse Replace the power cord Replace the component Replace the control board Replace the motor Replace the bearing assembly
Fuse Blown	<ol style="list-style-type: none"> 1 Faulty control board 2 Faulty motor 3 Bad power supply 4 Power cord damaged 	Replace the control board Replace the motor Replace fuse and try different power supply Replace the power cord
Table does not rotate smoothly.	<ol style="list-style-type: none"> 1 Bearing nut is loose 2 Bearing damage 3 Spatter from welding adhered to the gears 	Torque bearing nut to 13.2 ft-lbs Replace the bearing assembly Clean and apply grease to the gears
Table will not tilt	<ol style="list-style-type: none"> 1 Seized Adjustment Handle 	Lubricated and move in both directions to free up.

DAILY MAINTENANCE

- ✦ Inspect table ground for proper tension against table.
- ✦ Test operation of 3 position power switch
- ✦ Test operation of optional foot pedal if provided
- ✦ Check for any broken wires or loose connections
- ✦ Check for any damaged or worn parts



TT-500 Welding Positioner

WARRANTY

LIMITED WARRANTY: Subject to the terms and conditions hereof, **Bancroft Engineering**, Waukesha, WI warrants its products to be free from defects in workmanship and material at the time of delivery. **Bancroft Engineering** will honor warranty claims on products as a result of failure from a defect for a time period of 90 days from the date of sale to the original user. Upon return of the merchandise at the user's expense, **Bancroft Engineering** reserves the right to either repair or replace as necessary. This is the only warranty either expressed or implied covering this product.

Bancroft Engineering, LLC
21550 Doral Road Waukesha, WI 53186
Phone: (262)786-1880
www.bancrofteng.com

ELECTRICAL SCHEMATICS (1)

Main Control Board Wiring Diagram.

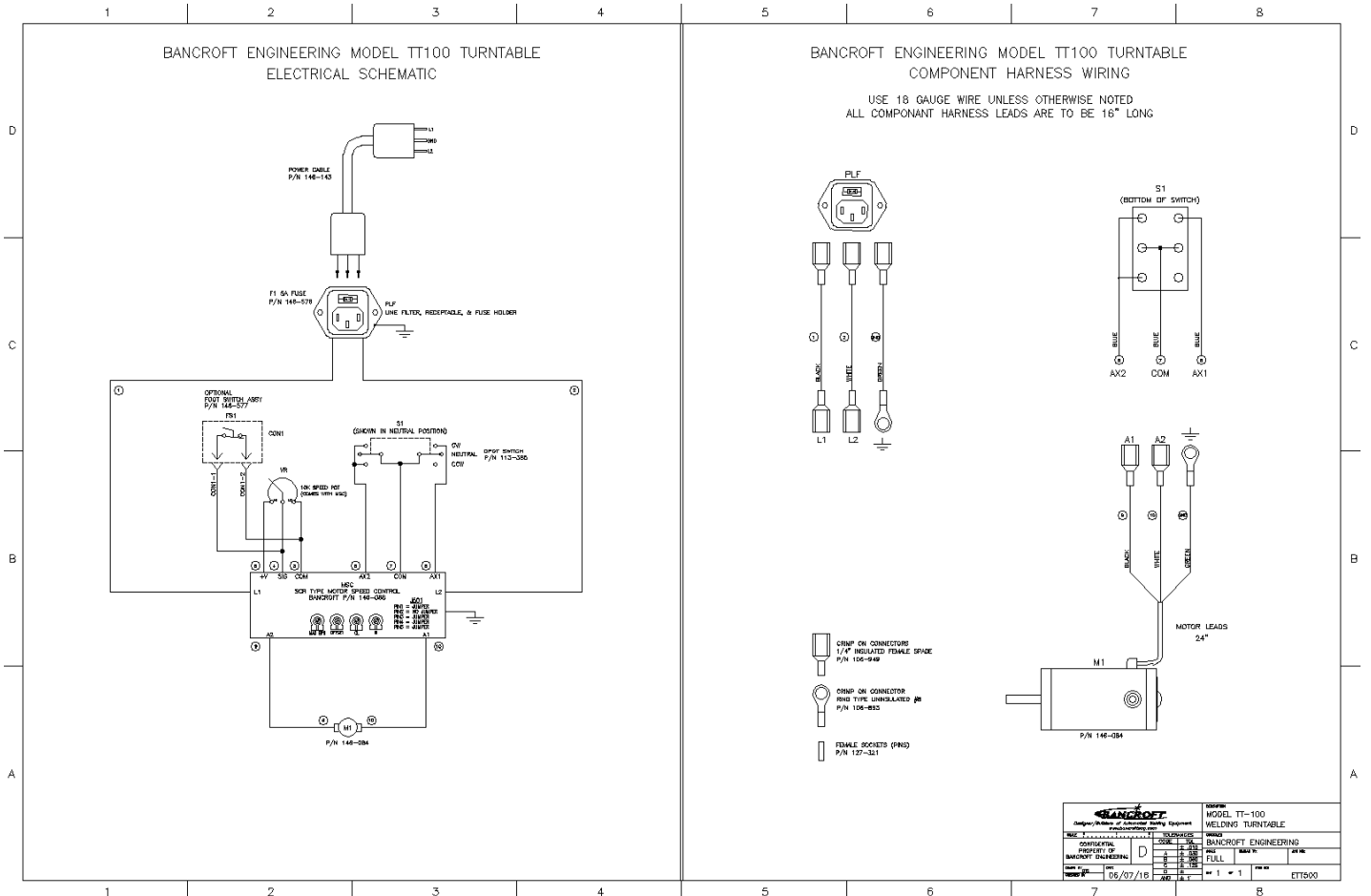

Service or repair of this unit must be done by qualified personnel only.



Before performing any maintenance on this control board disconnect the unit from any power supply.

ELECTRICAL SCHEMATICS (2)

Optional Foot Switch Wiring Diagram.

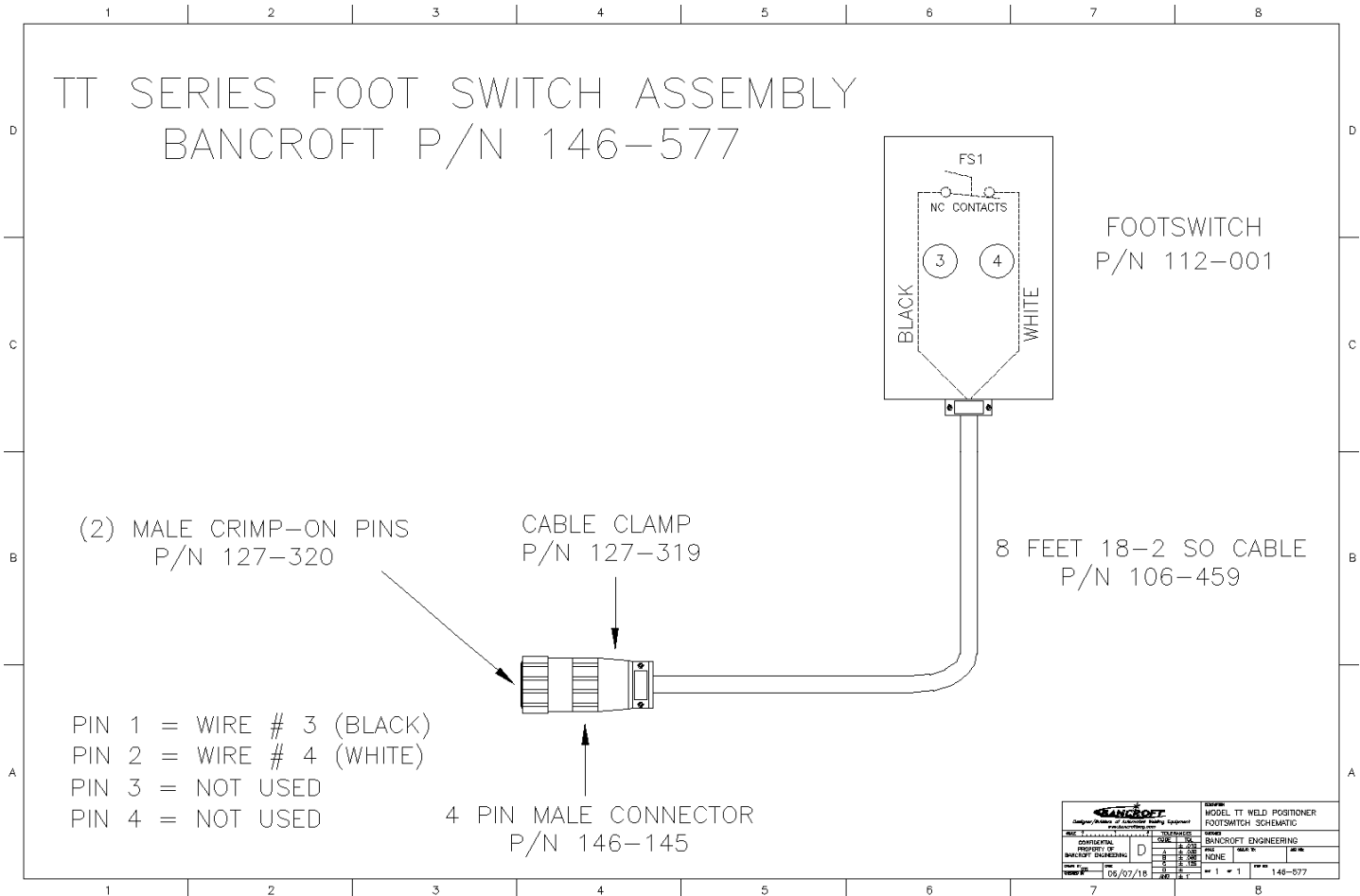

Service or repair of this unit must be done by qualified personnel only.



Before performing any maintenance on this control board disconnect the unit from any power supply.

PARTS LIST

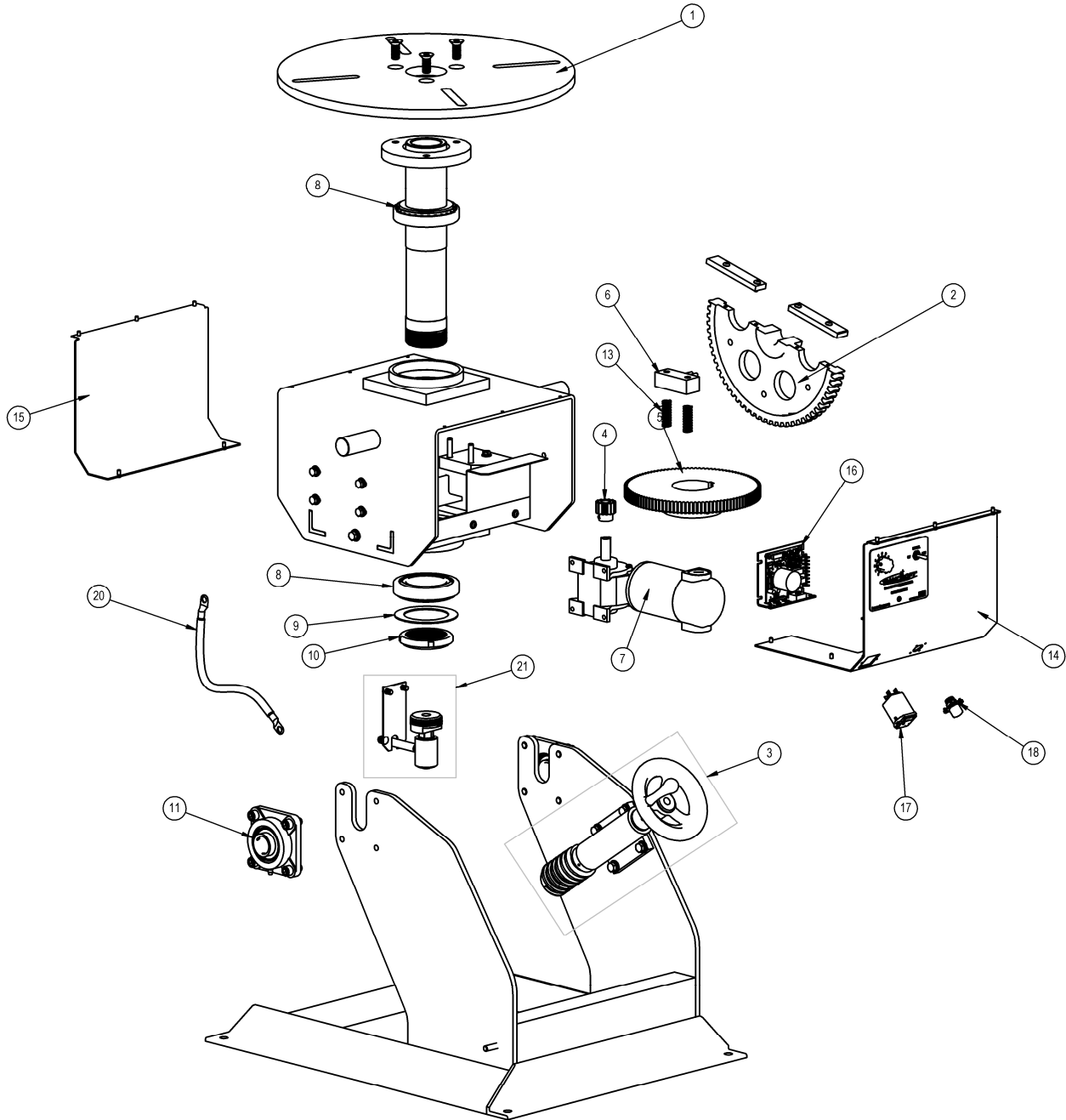



TT-500 Welding Positioner

ITEM	PART NO.	QTY	DESCRIPTION
1	146-898	1	Positioner Work Table
2	147-043	1	Worm Gear
3	127-703	1	Tilt Worm Assembly
4	147-280	1	Spur Gear, 14tooth, 12pitch, 14.5°PA
5	147-038	1	Spur Gear, Ø2.75 bore
6	104-259	1	Ground Brush Block
7	147-279	1	DC Gearmotor
8	147-034	2	Tapered Roller Bearing Ø2.75
9	147-095	1	Steel Shim Ø4.5 OD x Ø3 ID x .075 Thk.
10	131-621	1	Bearing Locknut, 2.751-18
11	147-039	2	Flange Bearing, 4-bolt, Ø1.25
12	147-030	1	Ground Brush Mtg. Block
13	119-789	2	Compression Spring
14	147-032	1	Control Plate / Cover
15	147-033	1	Back Cover
16	146-088	1	Speed Controller Assembly, Pre-wired
17	146-501	1	EMI Filter / Power Plug
18	146-144	1	4-Pin Receptacle
19	146-576	1	Fuse 5x20mm 5A Time Delay
20	147-282	1	Ground Cable
21	147-041	1	Purge Adapter OPTION

Bancroft Engineering, LLC

21550 Doral Road Waukesha, WI 53186

Phone: (262)786-1880

www.bancrofteng.com